

**Dual**

NEW TECH

# CD 20/150 CDP 4500

## Service-Anleitung Service Manual Instructions de Service

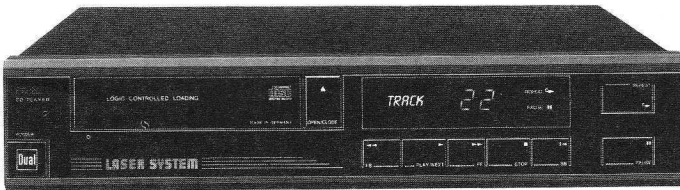

<b>Technische Daten</b> Meßwerte = typische Werte	<b>Technical data</b> Measured values = typical values	<b>Caractéristiques techniques</b> Valeurs mesurées = valeurs typiques	
<b>Frequenzbereich</b>	<b>Frequency response</b>	<b>Courbe de réponse</b>	20–20 000 Hz ± 0,5 dB
<b>Geräuschspannungsabstand</b>	<b>Signal to noise ratio</b>	<b>Rapport signal/bruit</b>	95 dB
<b>Dynamikbereich</b>	<b>Dynamic range</b>	<b>Dynamique</b>	92 dB
<b>Übersprechdämpfung (1 kHz)</b>	<b>Crosstalk (1 kHz)</b>	<b>Diaphonie (1 kHz)</b>	90 dB
<b>Klirrfaktor (1 kHz)</b>	<b>Harmonic distortion (1 kHz)</b>	<b>Distorsion harmonique (1 kHz)</b>	0,005 %
<b>Gleichlaufschwankungen</b>	<b>Wow and flutter</b>	<b>Pleurage et scintillement</b>	unmeasurable
<b>Intermodulationsverzerrung</b>	<b>Intermodulation distortion</b>	<b>Distorsion d'intermodulation</b>	0,01 %
<b>Fehlerkorrektur: Unterbrechung black dot</b>	<b>Fault correction: interruption black dot</b>	<b>Correction d'erreur: interruption black dot</b>	900 µm 800 µm
<b>Zugriffszeiten: Stop – Titel 1 Titel – Titel</b>	<b>Access times: stop – song 1 song – song</b>	<b>Temps d'accès: stop – titre 1 titre – titre</b>	2,5 s 0,5 s
<b>Ausgangsspannung (Hochpegelausgang)</b>	<b>Output voltage</b>	<b>Tension de sortie</b>	2 V
<b>D/A Wandler</b>	<b>D/A Converter</b>	<b>D/A Convertisseur</b>	16 Bit linear (Single)
<b>Abtastfrequenz</b>	<b>Pick up frequency</b>	<b>Fréquence d'pick-up</b>	44,1 kHz
<b>Abtastsystem</b>	<b>Recording system</b>	<b>Système d'enregistrement</b>	3-Strahl-Laser 3-beam optical pick up
<b>Leistungsaufnahme</b>	<b>Power consumption</b>	<b>Consommation</b>	18 W
<b>Netzspannung</b>	<b>Mains voltage</b>	<b>Tensions secteur</b>	230 V
<b>Netzfrequenz</b>	<b>Line frequency</b>	<b>Fréquence secteur</b>	50/60 Hz

Dual GmbH · Postfach 1144 · 7742 St. Georgen/Schwarzwald

# Abgleichanleitung · Alignment Instruction

Signalquelle Signal source	Einstellung Gerät Unit adjustment	Meßgerät Anschluß Testgear connection	Abgleichposition Alignment position	Abgleich – Bemerkung Alignment, Remarks
	Stop	<b>PLL</b>		
		1. BH 03 mit BX 03 brücken Bridge over BH 03 with BX 03		
		2. Frequenzzähler an / Frequency counter to BD 07 Pin 5	LD 06	4,321 MHz ± 3 kHz Achtung: CD 08, CD 09 mechanisch nicht verändern! Attention: Do not adjust CD 08 and CD 09!
		3. Brücke entfernen / Remove jumper		
<b>Focus Offset</b>				
		DC Voltmeter an / to BL 06	PL 20	0 V DC ± 20 mV
		<b>Tracking Offset</b>		
		DC Voltmeter an / to BL 05	PL 22	0 V DC ± 5 mV
Test Sample 5 A	Play Titel Nr. 2	<b>Radial Detector</b>		
		DC Voltmeter an / to BT 03	PT 31	0 V DC ± 10 mV
		Achtung: Spannung wird langsam nachgeregelt. Evtl. Titel neu anwählen. Attention: Align voltage slowly. If necessary, dial titel gain.		
		<b>Focus Gain</b>		
		AC Voltmeter an / to BF 02	PF 15	Max. Rechtsanschlag -3 dB Max. right-hand stop -3 dB
		<b>Tracking Gain</b>		
		AC Voltmeter an / to BT 03	PT 01	150 mV ± 20 mV
Endkontrolle: Titel Nr. 9 und 17 / Final test: Play titel no. 9 and 17				

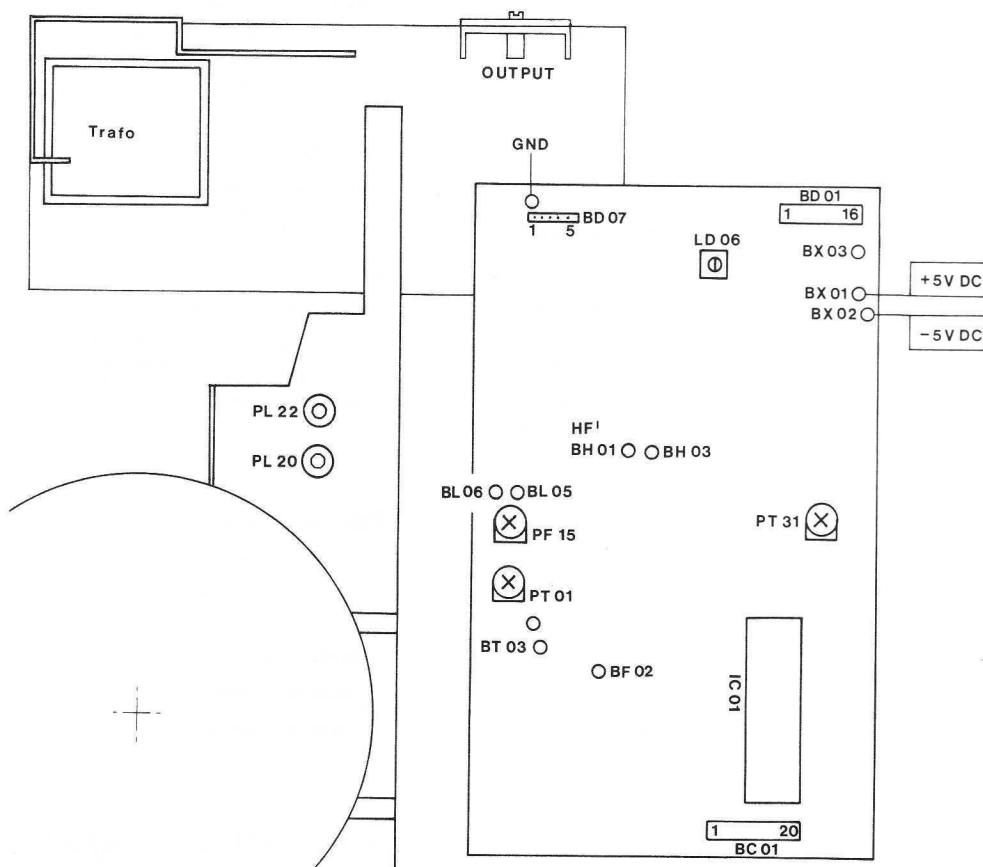

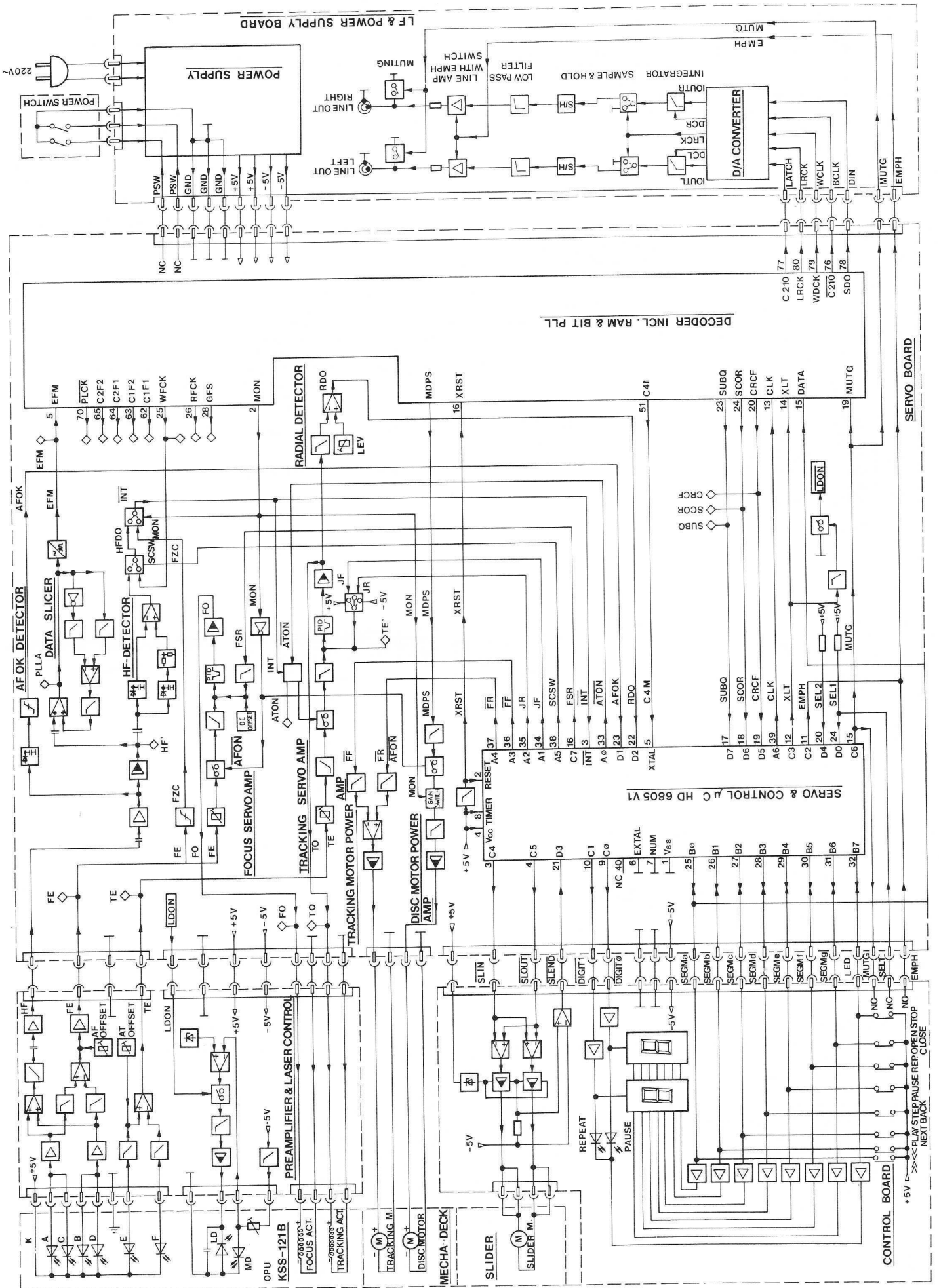

## IC CX 23035 · Pinbelegung · Pin arrangement

Pin	Name	Funktion
1	FSW	Disc motor output filter time constant select output
2	MON	Disc motor ON/OFF control output
3	MDP	Disc motor drive output. Rough control during CLV-S mode and phase control during CLV-P mode
4	MDS	Disc motor drive output. Speed control during CLV-P mode
5	EFM	EFM signal input from data slicer
7	MIRR	Input not used to GND
8	VCOO	VCO output. When locked to EFM signal, f = 8.6432 MHz
9	VCOI	VCO input
10	TEST	Input not used to GND
11	PDO	EFM signal and VCO/2 phase comparison output
12	Vss	GND
13	CLK	Serial data transfer clock input from CPU. Data latching clock rise edge
14	XLT	Latch input from CPU. Latching 8-bit shift register data (serial data from CPU) to respective registers.
15	DATA	Serial data input from CPU
16	XRST	System reset input
19	MUTG	Muting input with internal register A ATTM at low, normal state when MUTG is low and no sound when it is high.
20	CRCF	Output the CRC result of subcode Q
21	EXCK	Input not used to GND
23	SUBQ	Subcode serial output
24	SCOR	Subcode sync SO + S1 output
25	WFCCK	Write frame clock output. When frame synch is locked, f = 7.35 kHz
26	RFCK	Read frame clock output. Crystal system 7.35 kHz
28	GFS	Frame sync lock state display output
29	DB 08	External RAM data terminal. Data 8 (MSB)
30	DB 07	External RAM data terminal. Data 7
31	DB 06	External RAM data terminal. Data 6
32	DB 05	External RAM data terminal. Data 5
33	VDO	+ 5 V
34	DB 04	External RAM data terminal. Data 4
35	DB 03	External RAM data terminal. Data 3

Pin	Name	Funktion
36	DB 02	External RAM data terminal. Data 2
37	DB 01	External RAM data terminal. Data 1 (LSB)
38	RA 01	External RAM address output ADDR 01 (LSB)
39	RA 02	External RAM address output ADDR 02
40	RA 03	External RAM address output ADDR 03
41	RA 04	External RAM address output ADDR 04
42	RA 05	External RAM address output ADDR 05
43	RA 06	External RAM address output ADDR 06
44	RA 07	External RAM address output ADDR 07
45	RA 08	External RAM address output ADDR 08
46	RA 09	External RAM address output ADDR 09
47	RA 10	External RAM address output ADDR 10
48	RA 11	External RAM address output ADDR 11 (MSB)
49	RAWE	Write enable signal output to external RAM (active when low)
50	RACS	Chip select signal output to external RAM (active when low)
51	C4M	Crystal 1/2 frequency division output. f = 4.2336 MHz
52	Vss	GND
53	XTAI	Crystal oscillation circuit input. f = 8.4672 MHz
54	XTAO	Crystal oscillation circuit output. f = 8.4672 MHz
58	SLOB	Audio data output code select input (Two's complement when low)
59	PSSL	Audio data output mode select input (Serial output when low)
62	C1F1	Error correction state monitor output in C1 decoding
63	C1F2	Error correction state monitor output in C1 decoding
64	C2F1	Error correction state monitor output in C2 decoding
65	C2F2	Error correction state monitor output in C2 decoding
70	PLCK	VCO/2 output. When locking to EFM signal, f = 4.3216 MHz
73	VDO	+ 5 V
76	C210	C210 inversion signal
77	C210	Bit clock output. f = Crystal oscillator frequency / 4 = 2.1168 MHz
78	SDO	Audio signal serial data output
79	WDCK	88.2 KHz strobe signal output
80	LRCK	44.1 KHz strobe signal output

## IC HD 6805 V1P · Pinbelegung · Pin arrangement

Pin	Name	Funktion
1	Vss	GND (0 V)
2	RESET	System Reset Input (aktiv low)
3	INT	External Interrupt Input Pin
4	Vcc	+ 5 V dc
5	XTAL	External Clock Input – (Digital Signal Processor PIN 51)
6	EXTAL	low-Level (to GND)
7	NUM	low-Level (to GND)
8	TIMER	high-Level (to + 5 V)
9	CO	Digit 0
10	C1	Digit 1
11	C2	EMPH (EMPHasis) – Deemphasis ON/OFF
12	C3	XLT – (Digital Signal Processor PIN 14)
13	C4	SLIN (SLider IN)
14	C5	SLOUT (SLider OUT)
15	C6	MUTG (MUTinG) – (Digital Signal Processor PIN 19)
16	C7	FSR (Focus SeaRch)
17	D7	SUBQ (SUBcode Q-Kanal) – und (Digital Signal Processor PIN 23)
18	D6	SCOR – und (Digital Signal Processor PIN 24)
19	D5	CRCF – und (Digital Signal Processor PIN 20)
20	D4	high-Level (to + 5 V)

Pin	Name	Funktion
21	D3	SLEND (SLider END)
22	D2	RDO (Radial Detector Output)
23	D1	AFOK (Automatic Focus OK)
24	D0	high-Level (to + 5 V)
25	B0	Segment a
26	B1	Segment b
27	B2	Segment c
28	B3	Segment d
29	B4	Segment e
30	B5	Segment f
31	B6	Segment g
32	B7	LED
33	A0	ATON (Automatic Tracking ON)
34	A1	JF (Jump Forward)
35	A2	JR (Jump Rewind)
36	A3	FF (Fast Forward)
37	A4	FR (Fast Rewind)
38	A5	SCSW (SubCode SWitch)
39	A6	CLK (Clock) – (Digital Signal Processor PIN 13)
40	A7	frei

## Abkürzungen

MON	Motor ON
FE	Focus Error Signal
TE	Tracking Error Signal
HF	High Frequency
EFM	Eight to Fourteen Modulation
LDON	Laser-Diode ON
SCSW	Subcode Switch
JF	Jump Forward
JR	Jump Rewind
AFOK	Automatic Focussing
HFDO	HF-Detector Output
AFON	Automatic Focussing ON
SLIN	Slider IN
SLOUT	Slider OUT
SLEND	Slider End (-Position)
FZC	Focus Zero Cross

FSR	Focus Search
RDO	Radial Detector Output
FF	Fast Forward
FR	Fast Rewind
MUTG	Muting (Stummschaltung)
PLLA	PLL-Adjustment
TO	Tracking Servo Output
FO	Focus Servo Output
ATON	Automatic Tracking ON
AF-Offset	Automatic Focussing-Offset
AT-Offset	Automatic Tracking-Offset
AF-Gain	Automatic Focussing-Gain
AT-Gain	Automatic Tracking-Gain
LEV	LEVEL (Radial Detector)
EMPH	Emphasis-Deemphasis

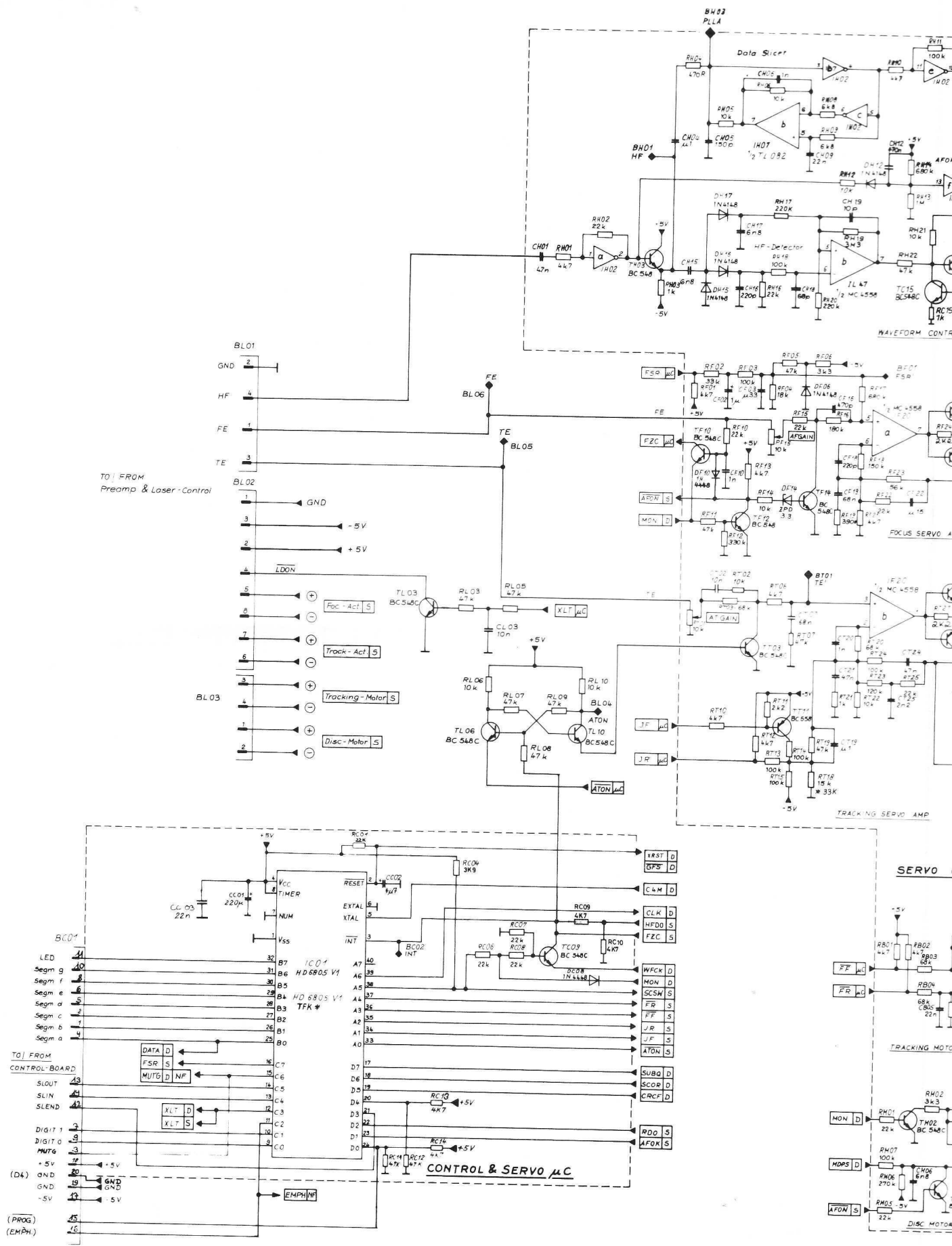

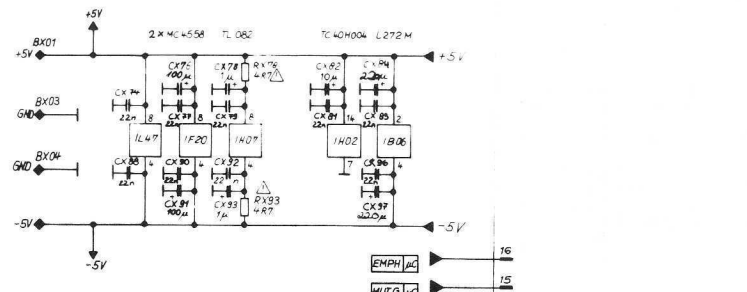
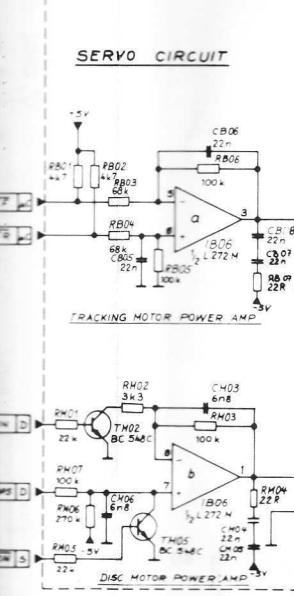
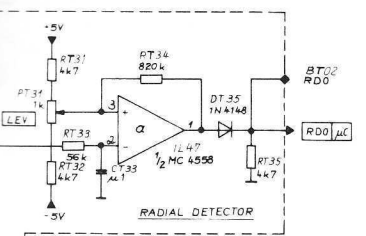
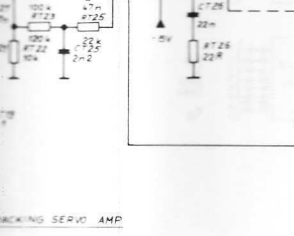
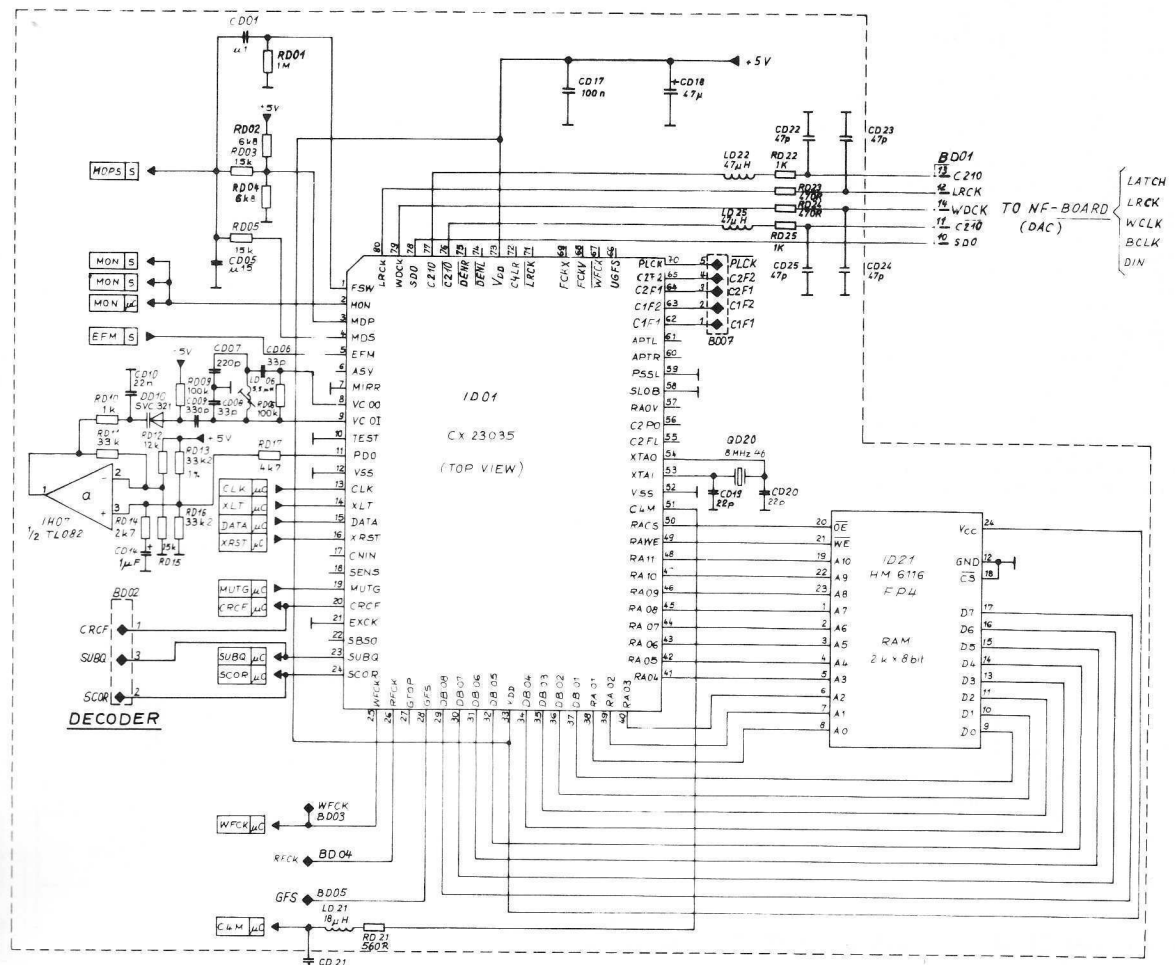
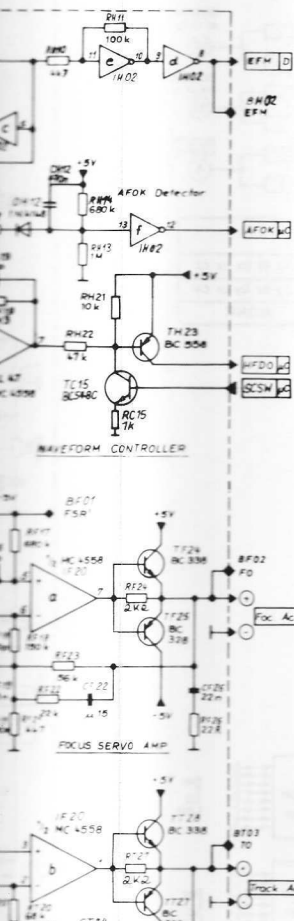

- FROM / TO**
- P PREAMP & LASER - CONTROL
  - S SERVO CIRCUIT
  - D CONTROL & SERVO  $\mu$ C
  - D DECODER
  - NF NF - BOARD
- ◆ Testpoint

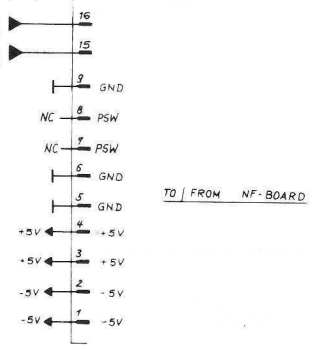

CX 20017

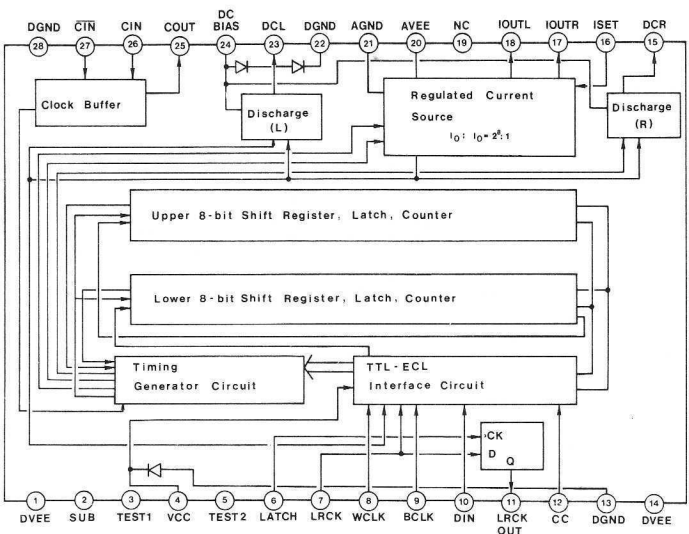

TEST1 and TEST2 are to be used open

HCF 4053

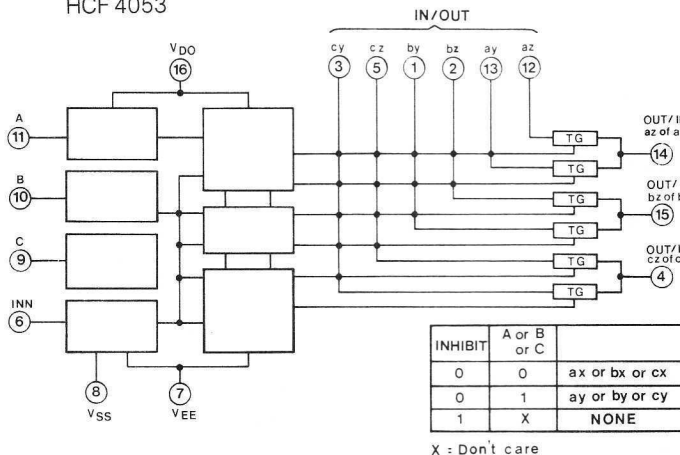

HM 6116

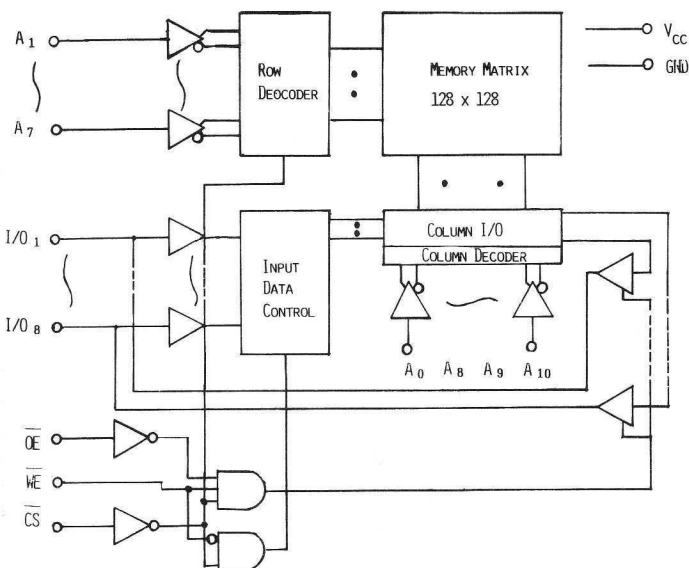

HD 6805 V1

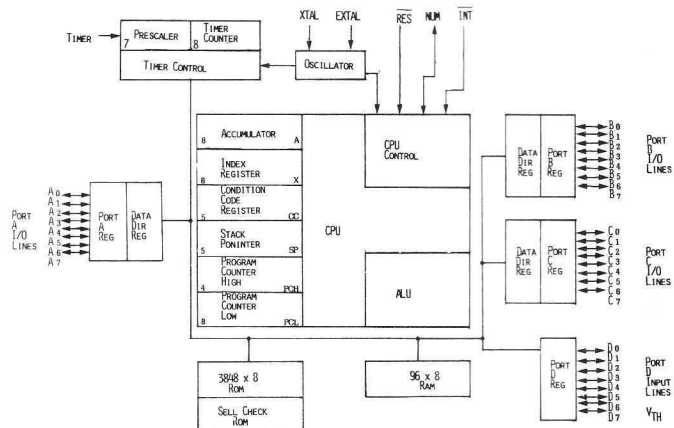

TL 40 H 004 P

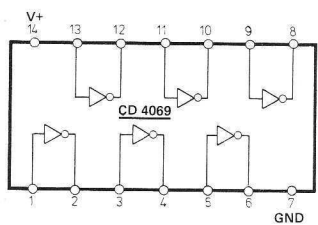

TL 082

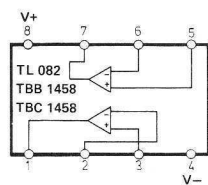

- MC 4558
- TL 082
- L 272
- RC 4560
- RC 5532

TL 40 H 004

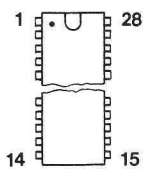

HM 6116

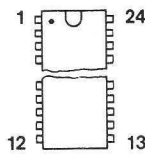

CX 20017

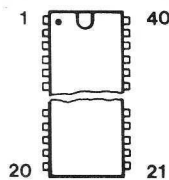

HD 6805

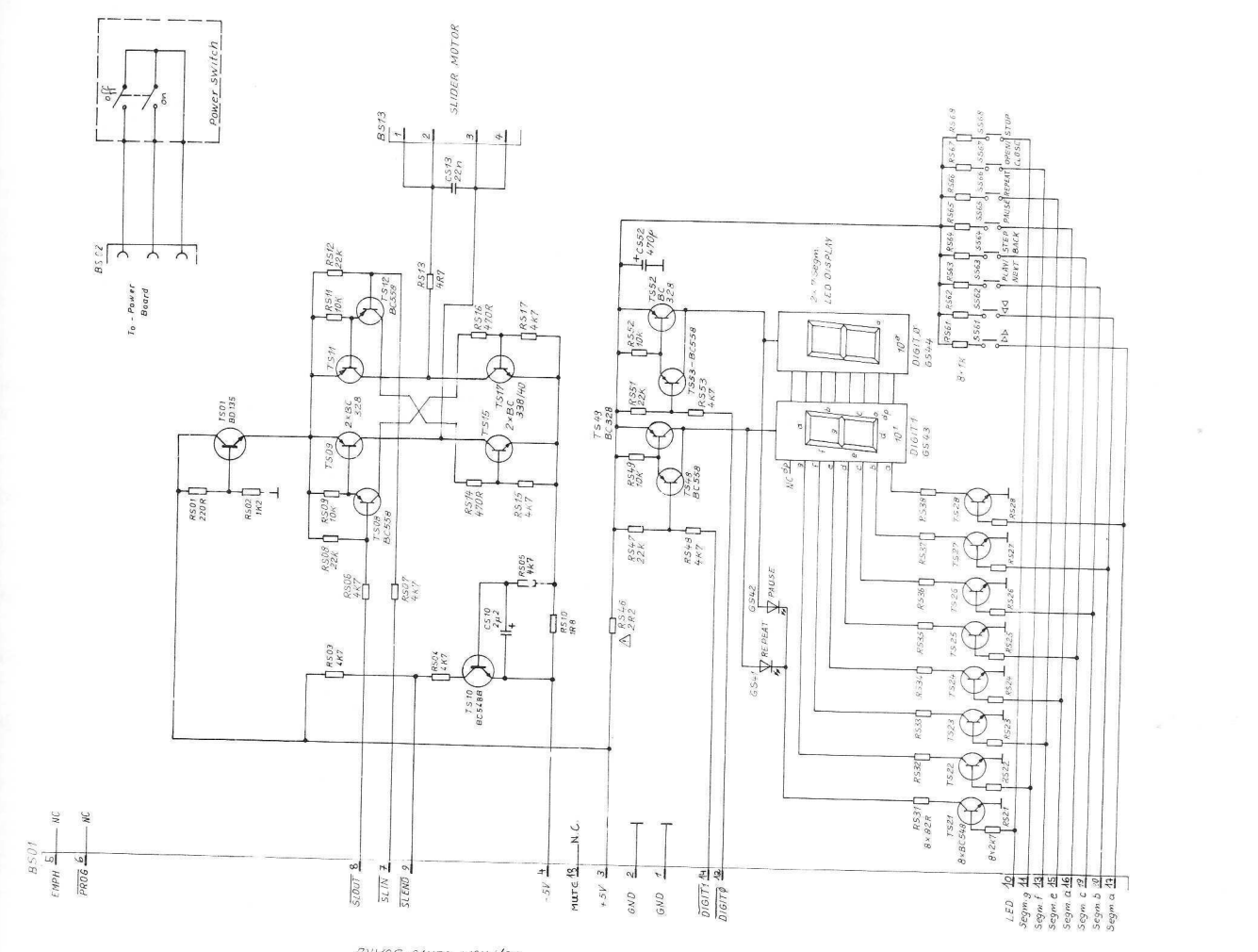
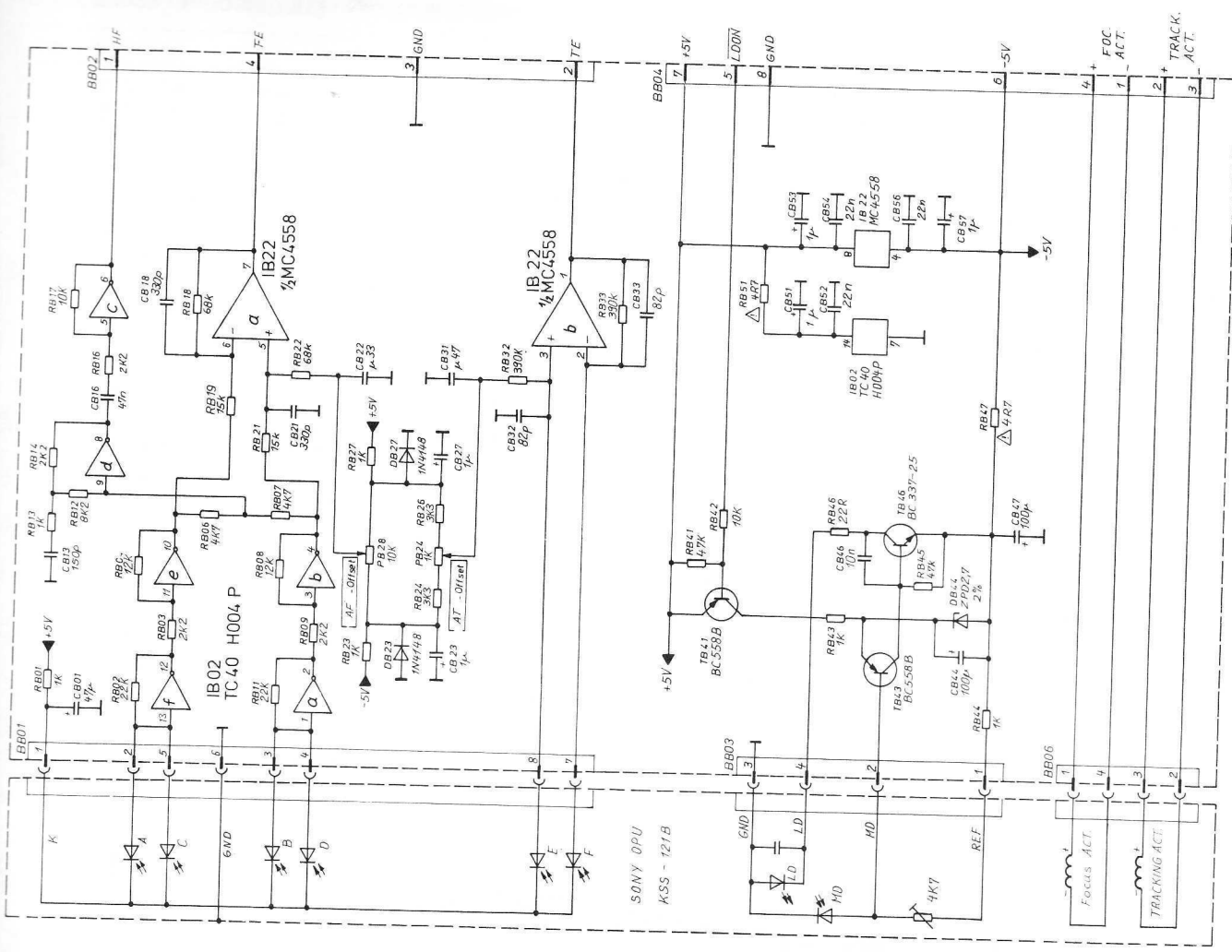



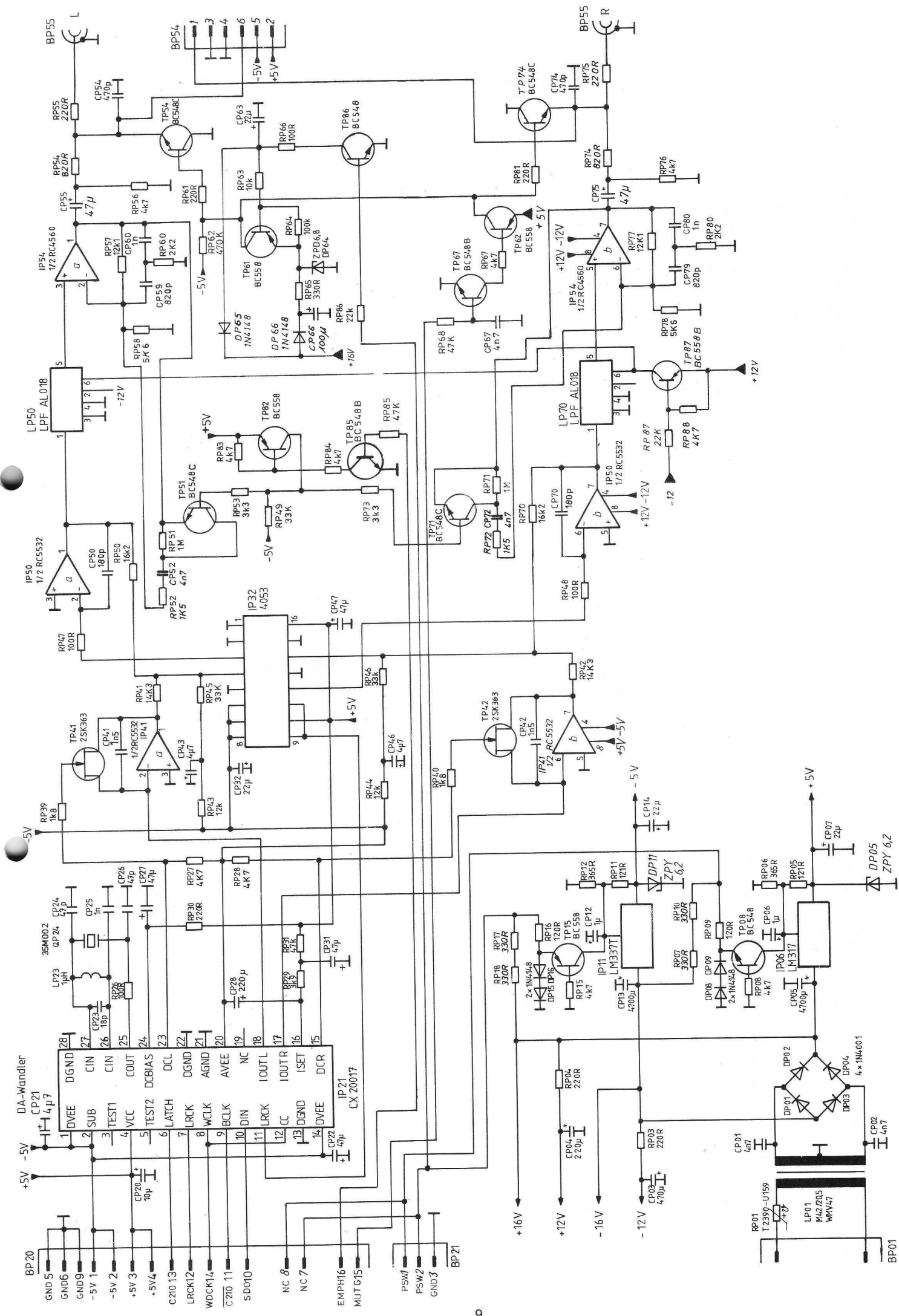

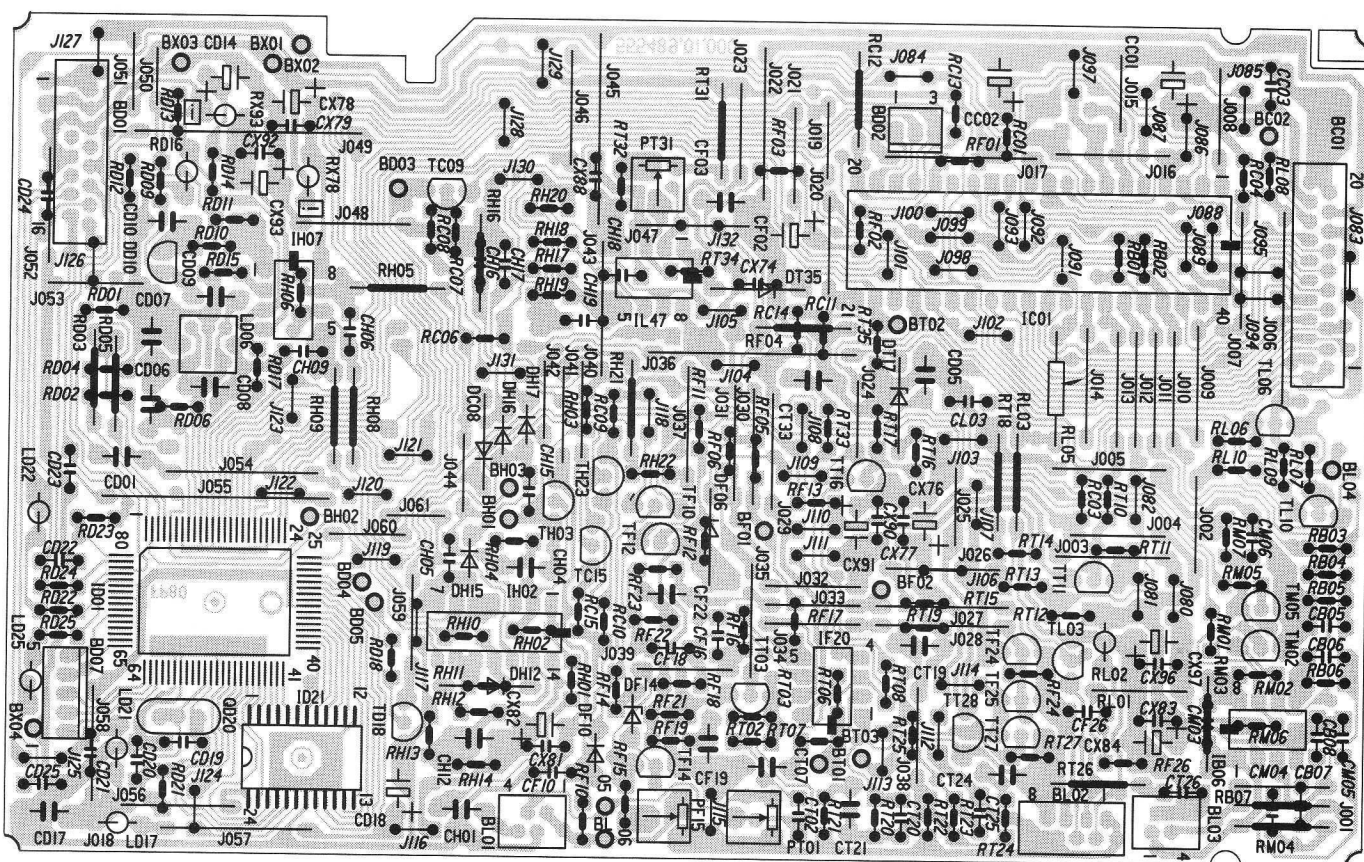
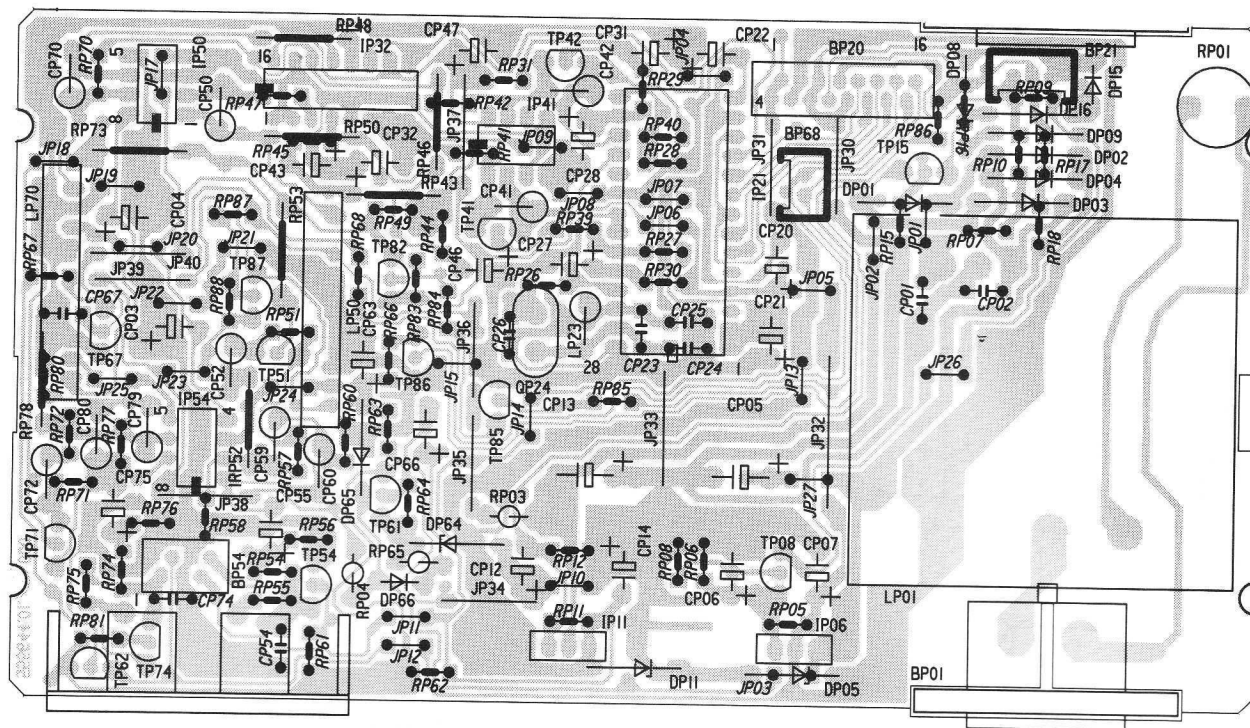

Tastenplatte  
 Key board  
 Platine de commande

Pickup-Platte  
 Pick up board  
 Platine de pickup

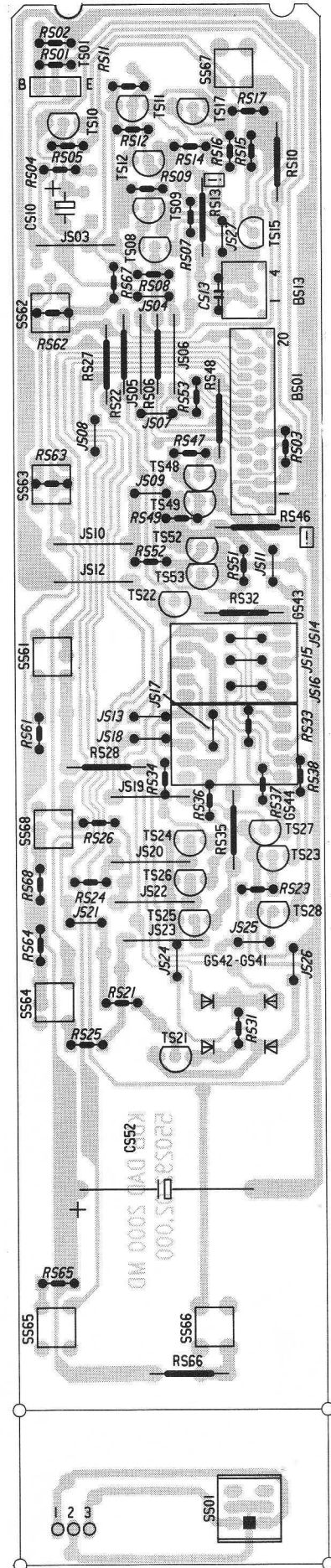
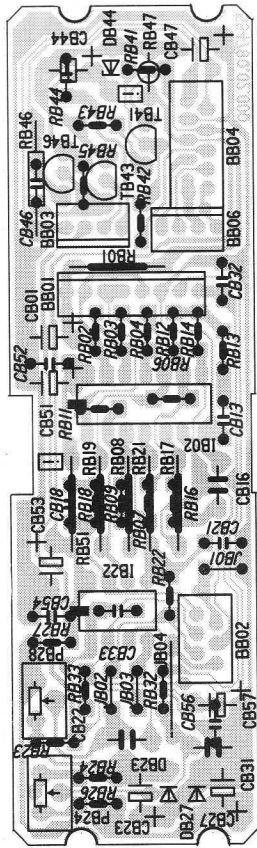

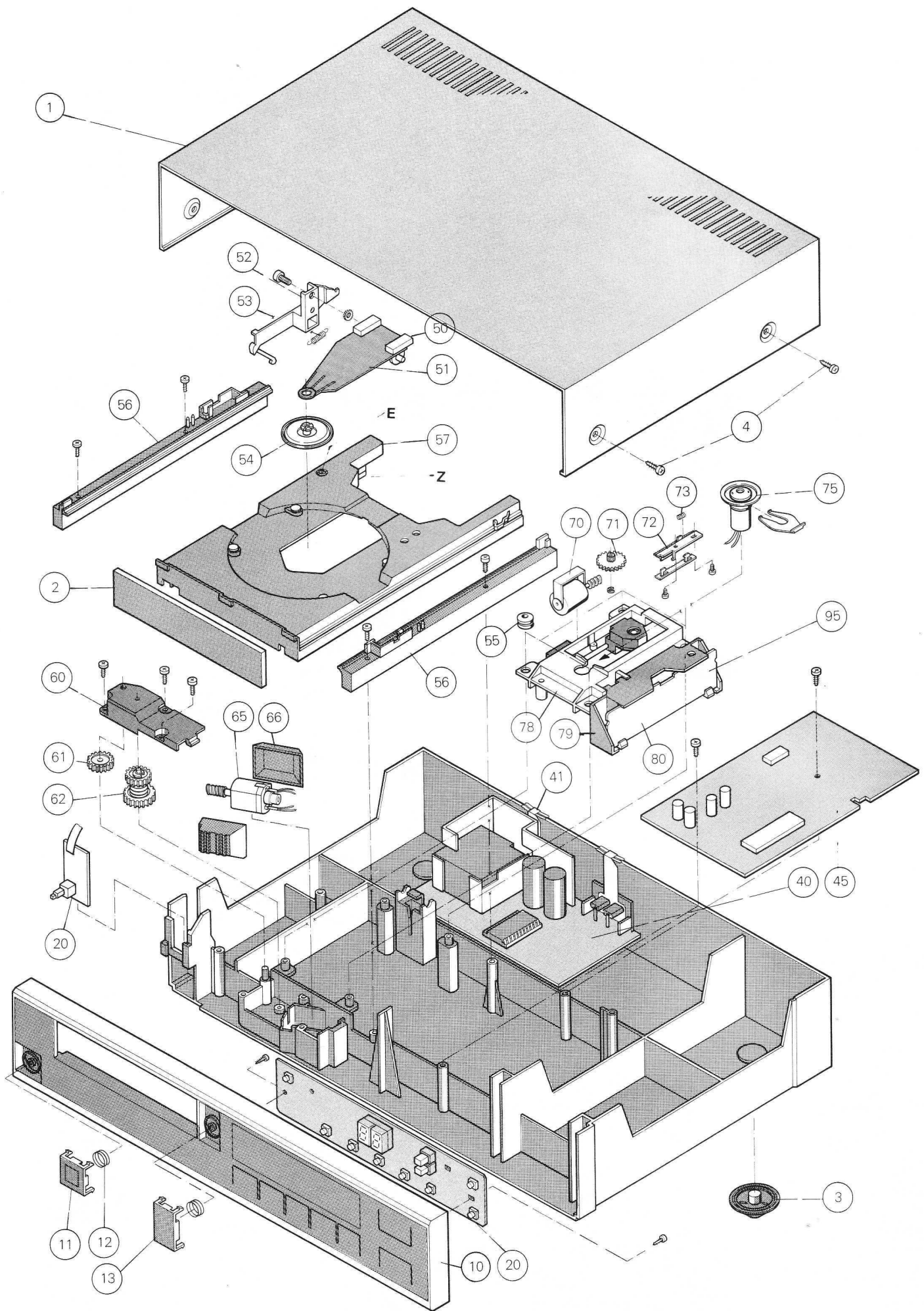

Ersatzteile · Replacement parts · Pièces détachées · CD 20/150

Pos.	Art.-Nr.	Stck	Bezeichnung
1	279271	1	Gehäuseblech GM
1	279358	1	Gehäuseblech PM
2	279346	1	Abdeckung
3	277540	4	Dämpfungsteil
4	279440	4	Linsenschraube 3,5 x 12
10	280875	1	Frontblende GM CD 20
10	280876	1	Frontblende PM CD 20
10	280877	1	Frontblende SI CD 150
10	281407	1	Frontblende CDP 4500
11	279273	1	Powertaste
12	279299	2	Druckfeder
13	279272	1	Taste
20	280885	1	<b>Tastenplatte</b>
21	280940	1	Display D 351 PA
GS 41	280886	2	Diode TLFR 1110
GS 42	280886	2	Diode TLFR 1110
RS 46	280887	1	Sicherungswiderstand 2,2/10/0,3
SS 1	280888	1	Schalter
SS 61	276045	8	Schalter
bis			
SS 68	276045	8	Schalter
TS 1	220608	1	Transistor BD 135
TS 8	277937	4	Transistor BC 558
TS 9	231062	1	Transistor BC 328
TS 10	240786	1	Transistor BC 548 B
TS 11	231062	1	Transistor BC 328
TS 12	277937	4	Transistor BC 558
TS 15	280136	2	Transistor BC 338-40
TS 17	280136	2	Transistor BC 338-40
TS 21	244715	7	Transistor BC 548 C
bis			
TS 28	244715	7	Transistor BC 548 C
TS 48	277937	4	Transistor BC 558
TS 49	231062	1	Transistor BC 328
TS 52	231062	1	Transistor BC 328
TS 53	277937	4	Transistor BC 558
40	280889	1	<b>Netz/Filterplatte</b>
41	280724	1	Massefeder
BP 1	279625	1	Gerätestecker
BP 55	279894	1	Cinchbuchse
DP 1	227344	4	Diode 1 N 4001
bis			
DP 4	227344	4	Diode 1 N 4001
DP 5	279931	2	Diode ZPY 6,2
DP 8	223906	3	Diode 1 N 4148
DP 9	223906	3	Diode 1 N 4148
DP 11	279931	2	Diode ZPY 6,2
DP 15	223906	1	Diode 1 N 4148
DP 16	223906	3	Diode 1 N 4148
DP 64	280898	1	Diode ZPD 6,8
DP 65	223906	3	Diode 1 N 4148
DP 66	223906	1	Diode 1 N 4148
IP 6	279927	1	IC LM 317 T
IP 11	280897	1	IC LM 337 T
IP 21	280890	1	IC CX 20 017
IP 32	280892	1	IC HCF 4053 BE MOS
IP 41	279914	2	IC NE 5532 N/RC 5532 N
IP 50	279914	2	IC NE 5532 N/RC 5532 N
IP 54	279915	1	IC RC 4560 N
LP 1	280893	1	Netztrafo
LP 23	280894	1	Drossel 1 MYH/20
LP 50	280895	1	Filter AL 018
LP 70	280896	2	Quarz 35 M 002
QP 24	280896	1	Quarz 35 M 002
TP 8	244715	3	Transistor BC 548 C
TP 15	277937	1	Transistor BC 558
TP 41	280899	2	Transistor 2 SK 363
TP 42	280899	2	Transistor 2 SK 363
TP 51	244715	3	Transistor BC 548 C
TP 54	244715	3	Transistor BC 548 C
TP 61	277937	2	Transistor BC 558
TP 62	277937	2	Transistor BC 558
TP 67	240786	1	Transistor BC 548 B
TP 71	244715	5	Transistor BC 548 C
TP 74	244715	5	Transistor BC 548 C
TP 82	277937	1	Transistor BC 558
TP 85	240786	1	Transistor BC 548 B
TP 86	244715	5	Transistor BC 548 C
TP 87	240787	1	Transistor BC 558 B
45	280900	1	<b>Servo-Platte</b>
DC 8	279930	1	Diode 1 N 4448

Pos.	Art.-Nr.	Stck	Bezeichnung
DD 10	275855	1	Diode SVC 321
DF 6	223906	3	Diode 1 N 4148
DF 10	279930	1	Diode 1 N 4448
DF 14	279895	1	Diode ZPD 3,3/BZX 83 C3V3
DH 12	223906	3	Diode 1 N 4148
DH 15	223906	3	Diode 1 N 4148
DH 16	223906	3	Diode 1 N 4148
DH 17	223906	3	Diode 1 N 4148
DT 35	223906	3	Diode 1 N 4148
IB 6	280901	1	IC L 272 M
IC 1	280903	1	IC MP HD 6805 V 1
ID 1	280905	1	IC CX 23 035 MOS
ID 21	280906	1	IC HM 6116 FP 4
IF 20	236299	2	IC RC 4558 D
IH 2	279905	1	IC 40 H 004 P MOS
IH 7	245236	1	IC TL 082 CP
IL 47	236299	2	IC RC 4558 D
LD 6	280907	1	Filter 7 x 7 8,46 MHZ
LD 21	280911	1	Drossel 18 MH
LD 22	280912	2	Drossel 47 MH
LD 25	280912	2	Drossel 47 MH
PF 15	280908	2	Steller 10 K
PT 1	280908	2	Steller 10 K
PT 31	280909	1	Steller 1 K
QD 20	280910	1	Quarz 8467,2 kHz
TC 9	244715	9	Transistor BC 548 C
TC 15	244715	9	Transistor BC 548 C
TF 10	244715	9	Transistor BC 548 C
TF 12	244715	9	Transistor BC 548 C
TF 14	244715	9	Transistor BC 548 C
TF 24	238894	1	Transistor BC 338
TF 25	231062	1	Transistor BC 328
TH 3	244715	9	Transistor BC 548 C
TH 23	277937	1	Transistor BC 558
TL 3	244715	9	Transistor BC 548 C
TL 6	244715	9	Transistor BC 548 C
TL 10	244715	9	Transistor BC 548 C
TM 2	244715	9	Transistor BC 548 C
TM 5	244715	9	Transistor BC 548 C
TT 3	244715	9	Transistor BC 548 C
TT 11	277937	1	Transistor BC 558
TT 27	231062	1	Transistor BC 328
TT 28	238894	1	Transistor BC 338
50	279017	2	Zuschnitt
51	276861	1	Andruckhebel
52	276862	1	Einstellhebel
53	278866	1	Zugfeder
54	280880	1	Magnethalter
55	279267	4	Dämpfungsteil
56	276885	1	Seitenführung
57	280299	1	Schublade
60	280111	1	Deckel
61	277305	1	Antriebsrad
62	280106	1	Kupplung
65	280882	1	Slider-Motor
66	280078	2	Dämpfungsschale
70	280883	1	Pickup-Motor
71	279339	1	Zahnradkupplung
72	280879	1	Zahnstange
73	279318	1	Druckfeder
75	280884	1	Disc-Motor
78	280878	1	<b>CD-Laufwerk</b>
79	280302	1	Halter
95	280916	1	<b>Pickup-Platte</b>
DB 23	223906	2	Diode 1 N 4148
DB 27	223906	2	Diode 1 N 4148
DB 44	280915	1	Diode ZPD 2,7/2%
IB 2	279905	1	IC 40 H 004 P MOS
IB 22	236299	1	IC RC 4558 D
PB 24	280913	1	Steller 1 K
PB 28	280914	1	Steller 10 K
TB 41	240787	2	Transistor BC 558 B
TB 43	240787	2	Transistor BC 558 B
TB 46	226870	1	Transistor BC 337-25
	279596	1	Netzkabel Euro
	226817	1	Tonabnehmerkabel Cinch
	279348	1	Bedienungsanleitung CD 20
	280640	1	Bedienungsanleitung CD 150
	279027	1	Faltschachtel
	280091	1	Seitenteil

Änderungen vorbehalten! Subject to change! Sous réserve de modification!

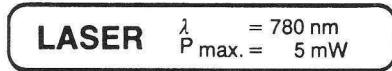

### Vorsicht

Das Gerät beinhaltet eine Laserkomponente, daher im Servicefall nachfolgende Hinweise unbedingt beachten:

- Das Gerät arbeitet mit unsichtbarer Laserstrahlung. Bei geöffnetem Gerät tritt unterhalb des Plattenhalters Laserstrahlung aus.
- Nicht in den Laserstrahl blicken.
- Hände und reflektierende Gegenstände nicht in den Laserstrahl bringen.
- Laserschutzbrille nach DIN 58 215 für die angegebene Wellenlänge tragen.
- Unbeteiligte Personen vom Arbeitsplatz fernhalten.

### Achtung

Die Einstellungen für den Laserstrahl am Laserabtaster und der LP-Platte dürfen nicht verstellt werden. Im Servicefall ist ein komplettes Laufwerk (Art.-Nr. 280878) fertig eingestellt im Austausch erhältlich.

### Justage-Hinweise

#### Schublade

- Manuelles Öffnen:** Dazu ist die Zahnstange (Z) nach vorne zu schieben.
- Spiel:** Linke Seitenführung (56) festschrauben dann Schublade mit rechter Seitenführung nach links drücken und festschrauben.
- Anschlag:** Mit dem Exzenter (E) wird die Schublade bündig mit der Frontblende eingestellt.

#### Andruckhebel

Die Höhe des Andruckhebels (51) ist so einzustellen, daß der Konus des Magnethalters (54) (bei eingelegter Platte) frei läuft.

### Caution

This CD-player operates with an invisible laser beam. If service is necessary please pay attention to the following notes:

- When the set is open, laser radiation emerges beneath the record holder arm.
- Do not look into beam.
- Do not expose hands or reflecting objects into laser beam.
- Please wear laser protective glasses according to DIN 58 215 for mentioned wave length.
- Please keep unconcerned people away from working place.

### Attention

It is not allowed to adjust positioning of laser beam at laser scanning and LP-plate.

If service is necessary a complete adjusted working gear (Art.-No. 280878) is available for exchange.

### Adjustment points

#### Drawer

- Manual opening:** The toothed rod (Z) has to be pushed forward.
- Play:** the left side-guidance (56) is fastened by screws, next the drawer has to be pushed to the left side with the right side-guidance and finally it has also to be fastened by screws.
- Stop:** With the eccentric (E) the drawer ended at the same height as the front panel.

#### Record holder arm

The height of the lever (51) has to be adjusted. So that the cone of the magnetic holder (54) is running free.